



**Installation Manual v1.1:
Ford Sub Zero Intercooler
'03-'07 6.0L Ford Trucks**

Please read all instructions before installation.



Figure 1 - Ford 6.0L Intercooler Kit

Prior to installation, visually inspect the ATS Sub Zero Intercooler for cracks, holes or damage. All intercoolers are carefully pressure tested, inspected and packaged but damage can occur during shipping. If intercooler arrives damaged, please contact ATS customer service.

Visually inspect the interior of the inlet and outlet tanks for debris. ATS Sub Zero Intercoolers are packaged to prevent anything from entering the tanks during shipping but ATS suggests double checking prior to installation.

If debris of any kind is present, position the intercooler so the inlet and outlet tubes are vertical. Shake the intercooler and lightly tap on the end tanks with a rubber mallet to dislodge trapped debris. Rinse thoroughly with clean water.

1. Park vehicle on level ground. Set parking brake.
2. Disconnect the negative (-) battery cables and secure them away from the negative battery terminals.

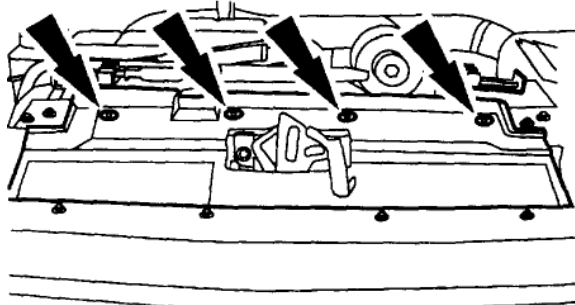

Figure 2 - Sight Shield Removal

3. Remove the air deflectors on each side of the A/C Condenser.

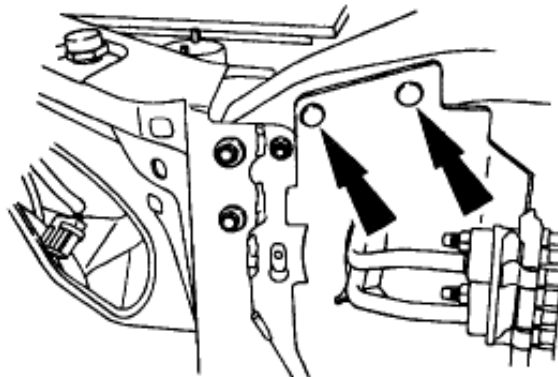

Figure 3 - Air Deflector Removal

4. Remove the upper A/C condenser support brackets.

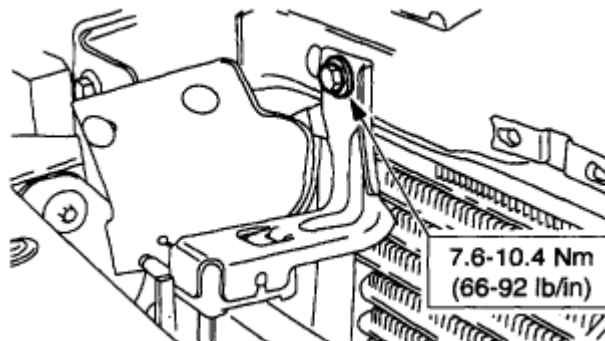

Figure 4 - A/C Condenser Support Bracket Removal

5. Remove the hood latch.

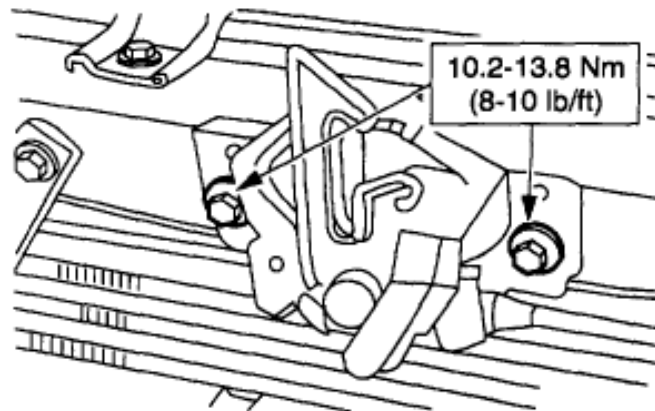

Figure 5 - Hood Latch Removal

NOTE: It is helpful to mark the outlined location of the latch with a pen or marker to ensure proper latch alignment when reassembled.

6. Remove the battery cable retainers to be able to move the battery cable back and out of the way.
7. Remove the intercooler support bolts and bushings. Set them aside as they will be reused later.

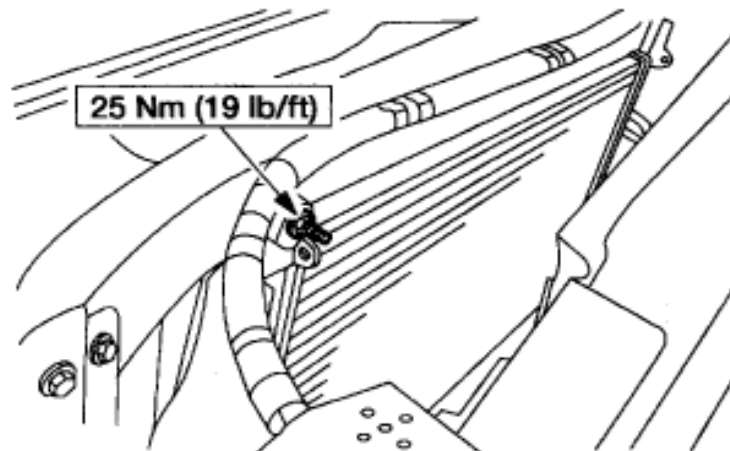

Figure 6 - Upper Intercooler Supports

8. Remove the upper radiator support. The support is held in by eight bolts, four on the back and four on the front. Remove the support by shifting it to one side inside the uprights and pull the opposite side up and out (a pry-bar can be helpful in this process).

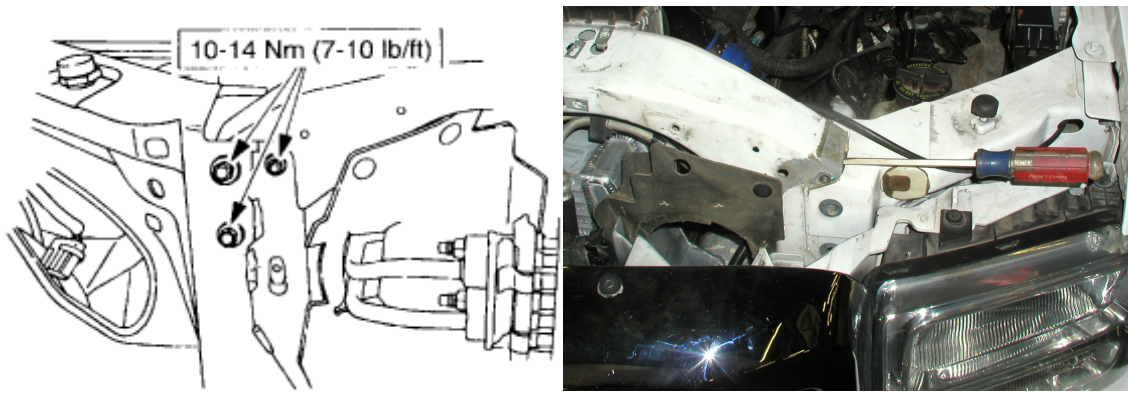

Figure 7 - Radiator Support Bracket Removal

9. Remove the factory plastic driver side charge tube and replace it with the steel charge tube supplied in the kit. Use the 3.5" long black boot supplied with the kit to connect the charge tube to the intake manifold. Reuse the factory clamp in this location and the one 3.25" clamp provided.

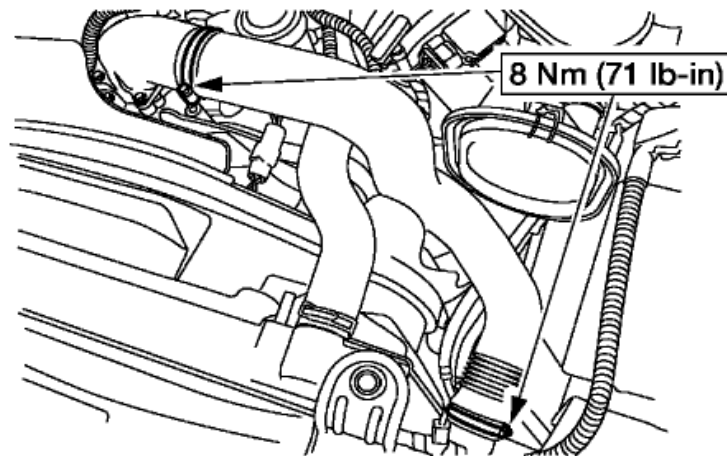

Figure 8 - Charge Tube Removal

10. Remove the stock intercooler boot clamps using a deep 11mm socket.
11. Discard the factory intercooler boots and clamps.

12. Pull the A/C condenser back slightly and swing it up and over the engine being careful not to bend the A/C lines. **Be very careful when performing this step. Do NOT disconnect the lines from the condenser.**



Figure 2 - Moved A/C Condenser

13. Remove the factory intercooler. Be sure not to damage the radiator when lifting the intercooler upwards.
14. With the factory intercooler out of the truck, remove the rubber grommets from the factory intercooler lower mounts and install them into the Sub Zero intercooler.
15. Remove the grommets from the factory intercooler top mounting brackets and install them into the Sub Zero intercooler top mounting brackets.
16. To install the ATS Sub Zero Intercooler, follow the removal procedure in reverse order noting the torque specs shown.
17. Connect the charge tubes to the intercooler using the 3 to 3.5" reducer boots provided in the kit. The reducer boots provided have an internal rib that will seat into the factory passenger side charge tube. Make sure the clamp is centered over the internal rib connection.

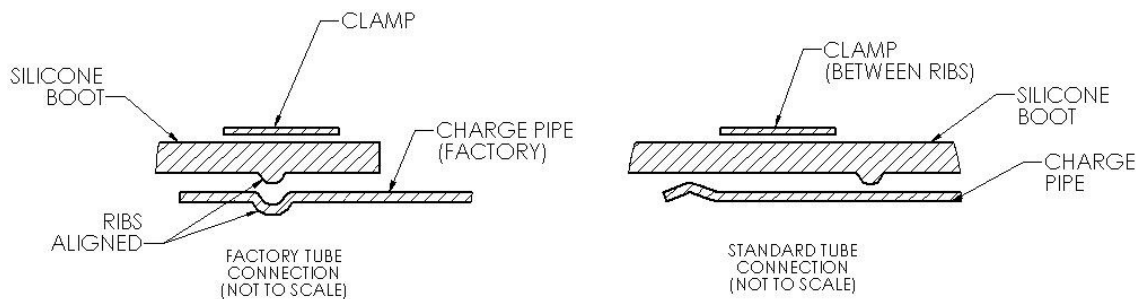

Have Any Questions?

Thank you for purchasing the Ford Sub Zero Intercooler. Please check our website at <http://www.atsdiesel.com> for technical support and other performance products such as the 5-Star™ torque converter, ATS High Performance Valve Body and ATS High Performance Transmission along with our full line of power enhancers. Please call or e-mail our Technical Service Department, 8:00am to 5:30pm Mountain Standard Time, Monday through Friday.

Contact Information

Toll Free: 800-949-6002

Local: 303-431-7973

Fax: 303-431-0135

Website: www.ATSDiesel.com

Email: info@ATSDiesel.com

We strive to make our instructions as clear and complete as possible. To achieve this, our instructions are under constant construction. We encourage you to visit our Technical Support Website (<http://www.atsdiesel.com/ATSWebSite/Technical.asp>) to check for the most up-to-date manuals and diagrams as well as other information. If you have any suggestions as to how we can improve this installation manual, let us know at <mailto:Suggestions@ATSDiesel.com>.

Bill of Materials

1. (1) ATS Sub Zero Intercooler 203-100-3224
2. (2) Intercooler Boots 202-019-1000
3. (2) 3.5" T-Bolt Clamp 94100-0350
4. (2) 4.0" T-Bolt Clamp 94100-0400
5. (1) 3" ID x 3.5" Long Boot 202-057-1000
6. (1) 3" Charge Tube 202-007-3278
7. (1) 3.25" T-Bolt Clamp 94100-0325

Not Pictured:

8. ATS Instructions
 - (1) Instruction Manual
 - (2) ATS Stickers