



**Installation Manual v1.2:  
Ford Sub Zero Intercooler  
'99-'03 7.3L Ford Trucks**

**Please read all instructions before installation.**

Note: Some aftermarket air intakes can interfere with intercooler installation.



Prior to installation, visually inspect the ATS Sub Zero Intercooler for cracks, holes or damage. All intercoolers are carefully pressure tested, inspected and packaged but damage can occur during shipping. If intercooler arrives damaged, please contact ATS customer service.

Visually inspect the interior of the inlet and outlet tanks for debris. ATS Sub Zero Intercoolers are packaged to prevent anything from entering the tanks during shipping but ATS suggests double checking prior to installation.

If debris of any kind is present, position the intercooler so the inlet and outlet tubes are vertical. Shake the intercooler and lightly tap on the end tanks with a rubber mallet to dislodge trapped debris. Rinse thoroughly with clean water and blow dry with compressed air.

1. Park vehicle on level ground. Set parking brake.
2. Disconnect the negative (-) battery cables and secure them away from the negative battery terminals.
3. Remove the emergency jack and mount.

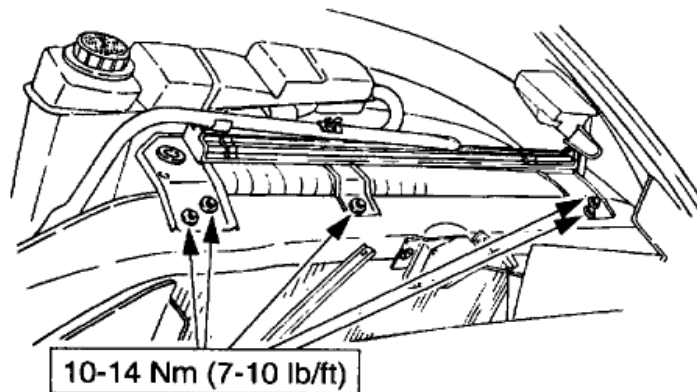

**Figure 2 - Jack Removal**

4. Remove the coolant reservoir retaining bolt.

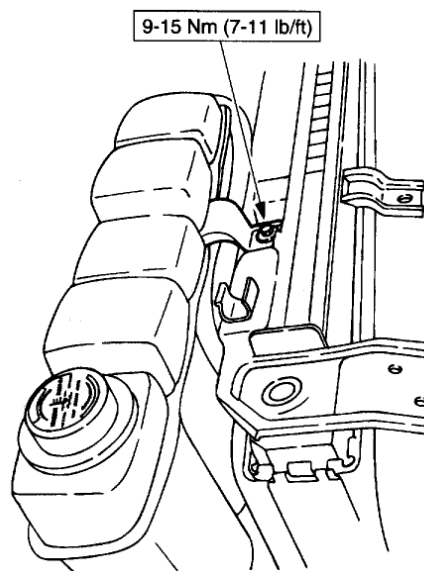

**Figure 3 - Coolant Reservoir Retainer Removal**

5. Remove the 9 pin-type retainers and remove sight shield.

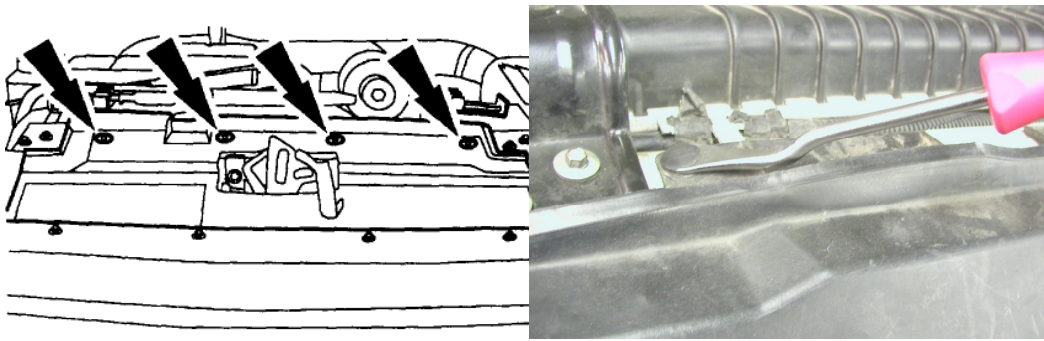

**Figure 4 - Sight Shield Removal**

6. Remove the air deflectors on each side of the A/C Condenser.

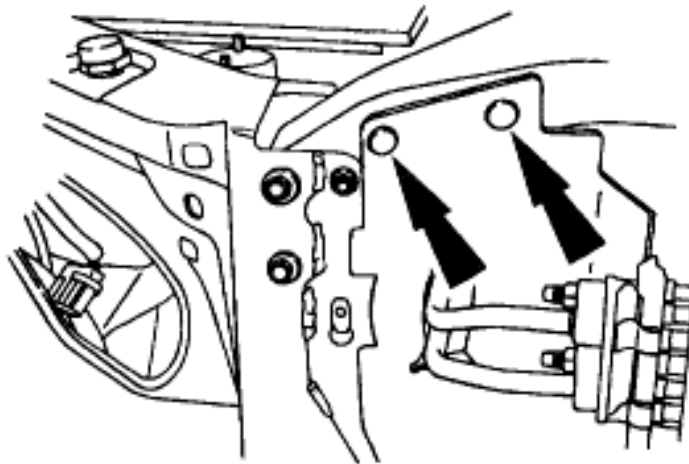

**Figure 5 - Air Deflector Removal**

7. Remove the upper A/C condenser support brackets.

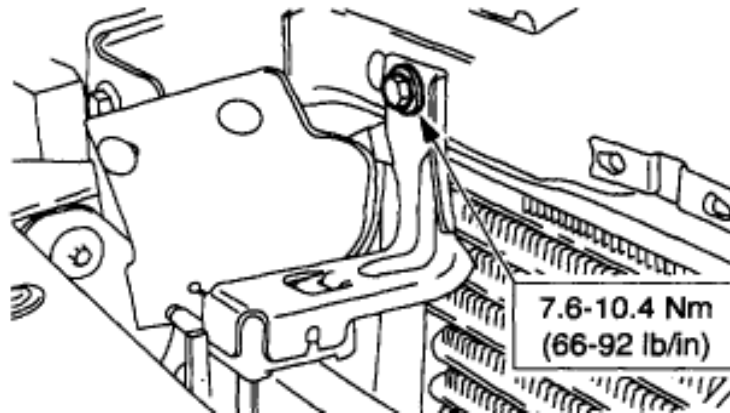

**Figure 6 - A/C Condenser Support Bracket Removal**

8. Remove the hood latch.

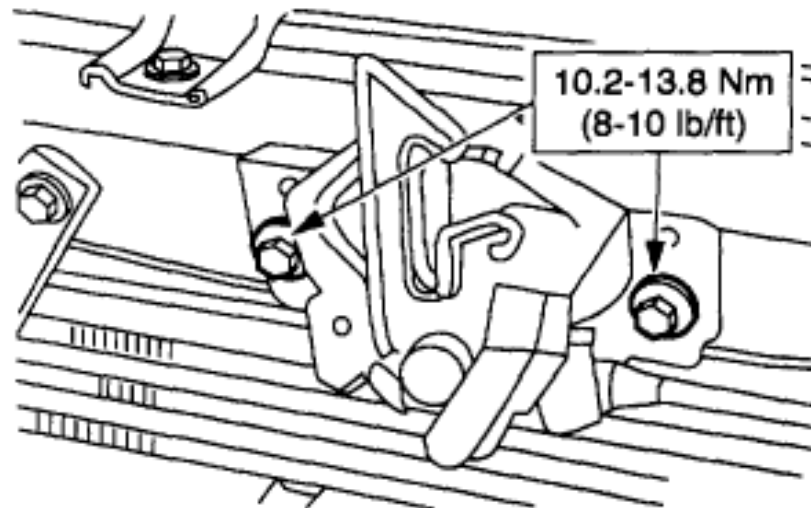

**Figure 7 - Hood Latch Removal**

NOTE: It is helpful to mark the outlined location of the latch with a pen or marker to ensure proper latch alignment when reassembled.

9. Remove the three battery cable retainers. Move the battery cable back and out of the way.
10. Remove the intercooler support bolts and bushings. Set them aside as they will be reused later.
11. Remove the upper radiator support. The support is held in by eight bolts, four on the back and four on the front. Remove the support by shifting it to one side inside the uprights and pull the opposite side up and out.

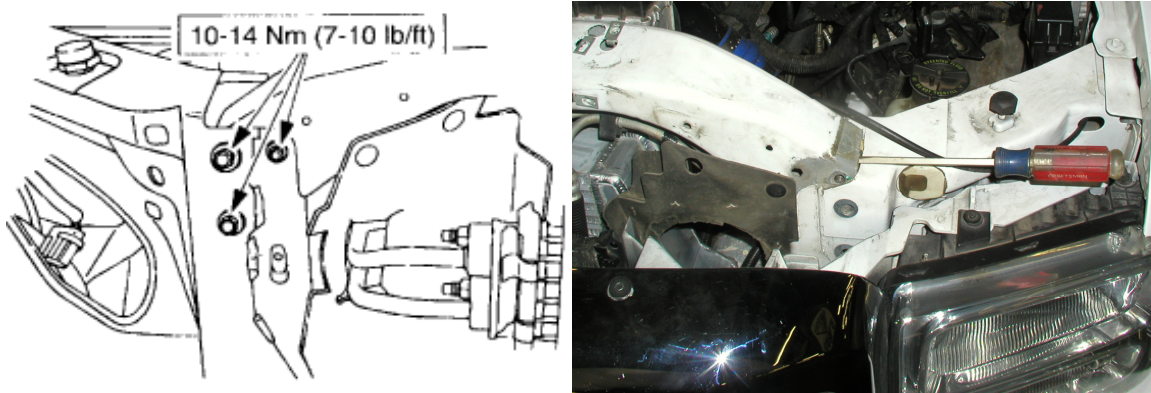

**Figure 9 - Radiator Support Bracket Removal**

12. Pull the A/C condenser back slightly and swing it up and over the engine being careful not to bend the A/C lines.



**Figure 10 - Moved A/C Condenser**

13. Remove the stock intercooler boots using a deep 11mm socket.
14. Remove the factory intercooler.
15. To install the ATS Sub Zero Intercooler, follow the removal procedure in reverse order noting the torque specs shown.
16. Prior to installing the intercooler, check to determine which factory transmission cooler is included with the vehicle. Some factory transmission coolers interfere with intercooler installation. Fittings and additional line are included with the kit to modify these lines if necessary.

Note: A brake line cutter is necessary to cut the lines properly.

Note: Some 7.3L transmission coolers have a fixed tube fitting on the passenger side port that cannot be easily modified to work with the ATS intercooler. The larger 2003-07 Ford 6.0L transmission cooler will drop in and fit with the ATS intercooler (Ford Dealer P/N: 5C3Z-7A095-B or 5C3Z-7A095-CA). If a TIG welder is available, cut off the fixed tube and weld on a section of 3/8 OD aluminum tubing. Drill the block on the top of the cooler for the 3/8 tubing. Position the tube so the end points upward toward the hood. Use the compression fittings provided to reconnect the cooler lines.

17. Replace the intercooler boots with the intercooler reducer boots (#2, Figure 1). Notice the silicone boots supplied with the kit have an internal rib that will seat into the grooves on the factory charge tubes. Be sure to center the clamp over the rib feature.

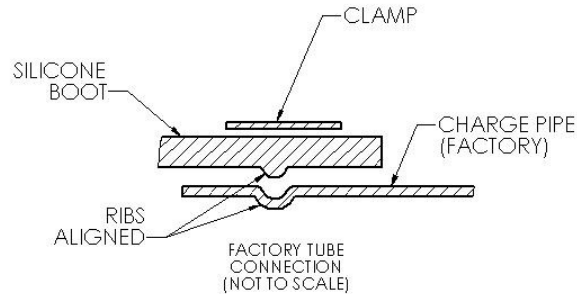

18. Replace the factory silicone boot on the driver side charge tube with the 3 inch x 4inch boot (#5, Figure 1) provided in the kit.

### **Have Any Questions?**

Thank you for purchasing the Ford Sub Zero Intercooler. Please check our website at <http://www.atsdiesel.com> for technical support and other performance products such as the 5-Star™ torque converter, ATS High Performance Valve Body and ATS High Performance Transmission along with our full line of power enhancers. Please call or e-mail our Technical Service Department, 8:00am to 5:30pm Mountain Standard Time, Monday through Friday.

### **Contact Information**

Toll Free: 800-949-6002  
 Local: 303-431-7973  
 Fax: 303-431-0135  
 Website: [www.ATSDiesel.com](http://www.ATSDiesel.com)  
 Email: [info@ATSDiesel.com](mailto:info@ATSDiesel.com)

We strive to make our instructions as clear and complete as possible. To achieve this, our instructions are under constant construction. We encourage you to visit our Technical Support Website (<http://www.atsdiesel.com/ATSWebSite/Technical.asp>) to check for the most up-to-date manuals and diagrams as well as other information. If you have any suggestions as to how we can improve this installation manual, let us know at <mailto:Suggestions@ATSDiesel.com>.

## **Bill of Materials**

1. (1) ATS Sub Zero Intercooler 203-100-3224
2. (2) 3.0" to 3.5" Intercooler Boots 202-019-1000
3. (2) 3.5" T-Bolt Clamp 94100-0350
4. (2) 4.0" T-Bolt Clamp 94100-0400
5. (1) 3" x 4" Intercooler Boot 202-057-1000
6. (2) 3/8" Compression Fitting 66CA-6-4
7. (2) 1/4 NPT to 3/8" Barbed Fitting 30182-4-6B
8. (6') 3/8" Hose 836-6

Not Pictured:

9. ATS Instructions
  - (1) Instruction Manual
  - (2) ATS Stickers